

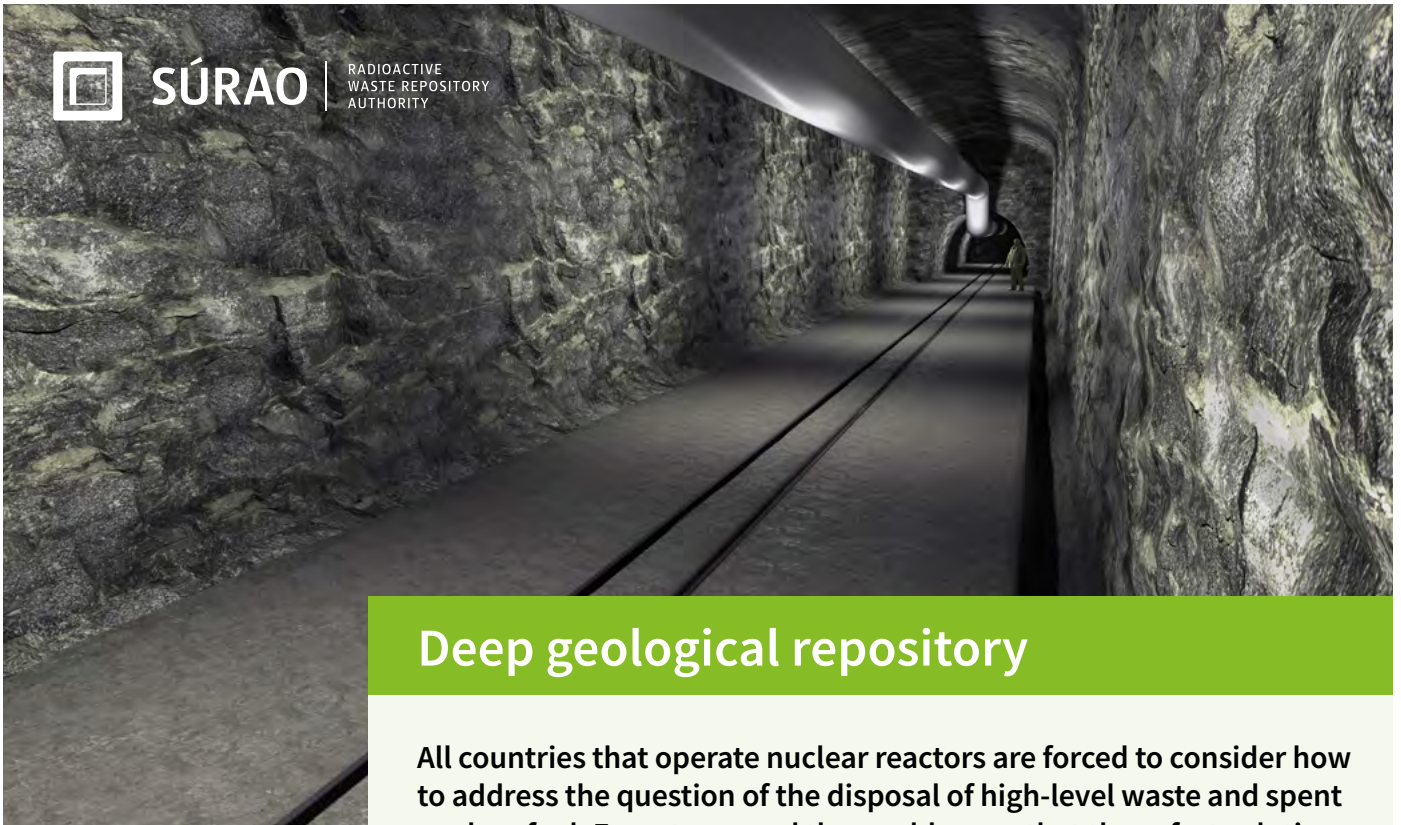

SÚRAO

RADIOACTIVE
WASTE REPOSITORY
AUTHORITY



Deep geological repository

All countries that operate nuclear reactors are forced to consider how to address the question of the disposal of high-level waste and spent nuclear fuel. Experts around the world agree that the safest solution is to build a deep geological repository that safely isolates such waste from the environment for hundreds of thousands of years.

Deep geological repositories (DGR) work on the basis of a system of engineered and geological barriers. The most significant barrier consists of 500 metres of stable rock which, in combination with the engineered barriers, shields the biosphere from radioactivity over a period of hundreds of thousands of years. Although in terms of human existence this is an unimaginably long time, certain geological formations remain unchanged even over hundreds of millions of years.

Several types of rocks are being studied around the world, which in specific geological conditions can be assumed to have the required properties. Research in the Czech Republic is focusing on crystalline, i.e. igneous transformed rock formations (granites, gneisses).

The other, i.e. engineered barriers consist of the double-skinned metal waste container, a special clay (bentonite) buffer and backfill material, and concrete structures. The selection of the most suitable materials for the production of the waste container will be based on the results of intensive research on the properties of various metals. The containers will be hermetically sealed and backfilled with the bentonite mixture which is both inert and impermeable to water. Moreover, research to date indicates that bentonite is able to retard the transport of radionuclides for up to several tens of thousands of years.

Natural analogues

When studying the long-term behaviour of disposal systems, the study of natural and artificial analogues provides an important source of information. Such analogues consist of phenomena or processes that are similar to those expected in the future DGR. Based on their behaviour in the past, it is possible to predict the behaviour of the disposal system once the DGR has been closed.

The Oklo natural nuclear reactor comprises one of the world's most famous natural analogues. Two billion years ago, a chain fission reaction took place in a uranium deposit in Gabon, Africa, that lasted for around half a million years. The long-term products of the reaction such as neptu-

nium and plutonium move extremely slowly in the nearby environment, i.e. at a rate of a mere 10 metres per 1 million years. It can reasonably be assumed, therefore, that under the same or similar natural conditions, plutonium and other radionuclides from spent nuclear fuel disposed of at a depth of at least 500 m will never reach the biosphere.

A similar natural analogue has also been studied in the Czech Republic, which is known for its numerous uranium ore deposits. The study involved the investigation of the movement of uranium deposited in clay layers at Ruprechtov in Western Bohemia. It was found that the clay with which the uranium ore is surrounded retards the transport of uranium to the surface so that it does not occur in the environment at all.

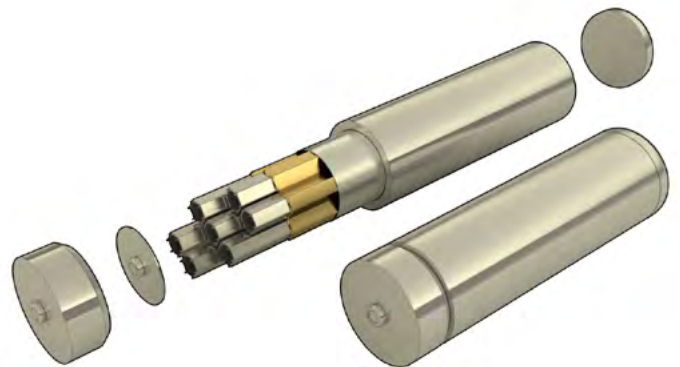

Visualisation of a spent nuclear fuel disposal container

What will the deep geological repository look like?

A study of the design of the Czech deep geological repository has already been conducted, and it will be further developed and modified according to the results of geological survey work at the candidate sites, the characteristics of the finally selected site and economic and technical considerations. The appearance of the repository may also be influenced by the conditions set by the affected municipalities. Inspiration is also available from countries with more advanced deep geological repository projects (e.g. Finland and Sweden), from which the Czech design will not differ significantly.

The deep geological repository for high-level waste, which includes spent nuclear fuel, will have two main components, i.e. a surface area and an underground complex with the disposal spaces, which will be connected via a system of access shafts and tunnels. Currently, the deep geological repository design concept is based on the assumption that both construction and operation (i.e. the disposal of radioactive waste) will take place concurrently; the two sections (construction and operation) will be physically separated from each other.

Surface area

The largest part of the surface area (approx. 90%) will be taken up by production and technical facilities related to the mining work involved in the construction of the underground section of the repository and the production of bentonite and bentonite segments. The reception of the containers with the radioactive waste will take place in a relatively small and secured part of the surface complex. In addition, the surface area will include administrative and operational buildings (offices, changing rooms, a canteen, workshops, etc.), production facilities (e.g. for the production of bentonite prefabricates, cooling water etc.), storage buildings (for empty transport containers, oil storage etc.) technical equipment (transformer station, water treatment plant) and a handling area for the removal of rubble from the mined tunnels.

Underground area

The greater part of the underground area will consist of the extensive network of corridors in which the containers with radioactive waste will be disposed of. The disposal corridors will be excavated at a depth of approximately 500 metres below the Earth's surface (according to conditions at the chosen site). The spent nuclear fuel containers will be disposed of in excavated chambers either horizontally or vertically. The other radioactive waste will be disposed of in concrete containers placed in disposal chambers. Currently, the envisaged capacity of the repository will be sufficient for the disposal of the waste produced by the Czech Republic's existing nuclear power plants and three planned new nuclear reactor blocks.

Construction of the deep geological repository

The current timetable foresees the commencement of the construction of the deep geological repository in 2050. The construction of the facility will be preceded by the construction of an underground laboratory which will serve for the on-site confirmation of the properties of the selected rock complex. As with all industrial construction projects, the deep geological repository will exert a certain influence on the landscape; however, unlike most other such projects, it will present the affected region with a number of benefits, the most important of which will include financial contributions to the area, increased employment opportunities, significant investment in the local infrastructure and the development of tourism and local transport services.

The construction and operation of the deep geological repository will proceed via a number of stages, each of which will involve the employment of several dozen people. In the initial stages (geological survey work, construction of the underground laboratory and the commencement of the construction of the repository itself), it is assumed that local human resources will be required to the extent of up to around 20% of the total workforce, while the rest will be external workers. However, with the ongoing construction and commencement of operation of the repository, the situation will be reversed, i.e. an estimated 80% of the workforce will be made up of local residents. The current assumption is that 140–200 job positions will be created during the current construction phase and up to 250 during operation.

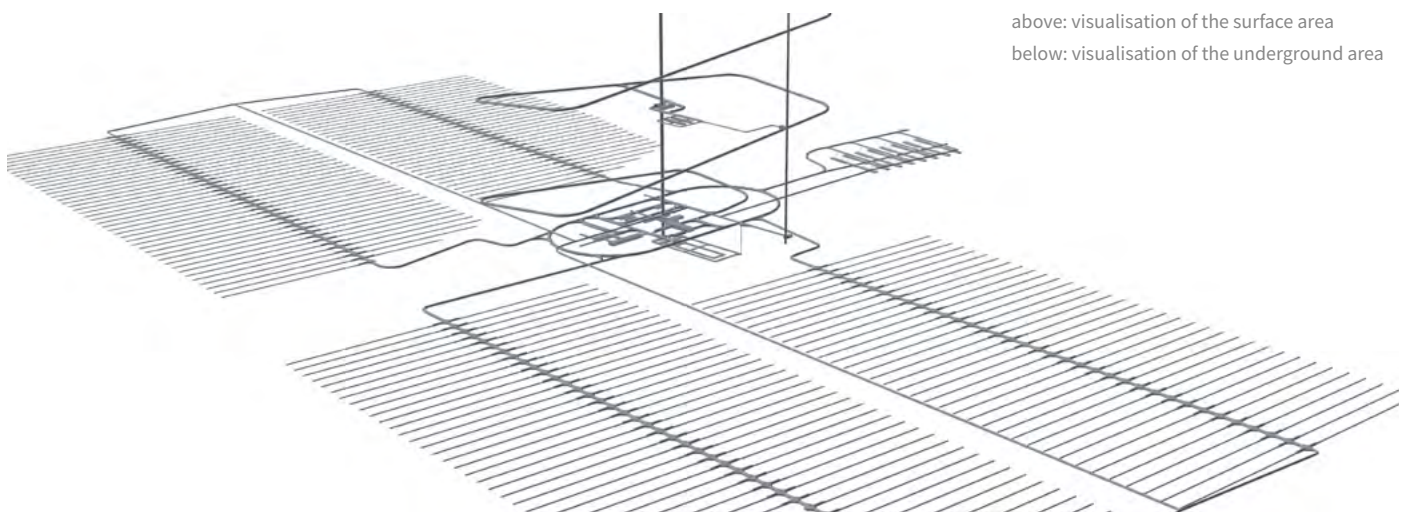
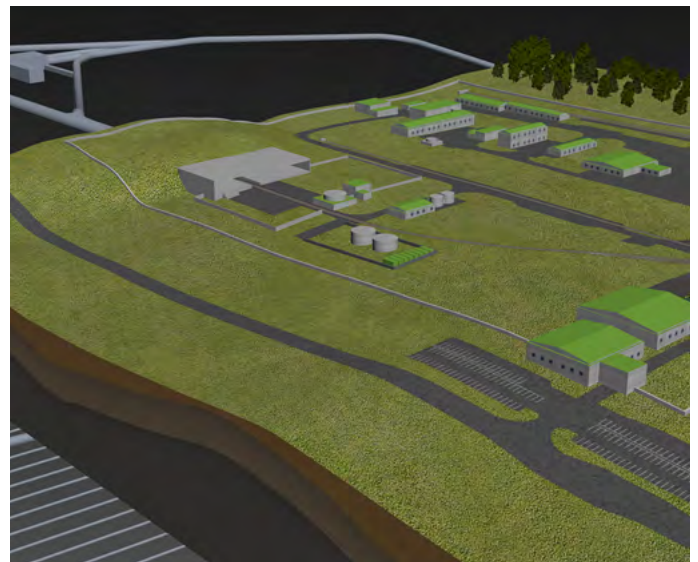

above: visualisation of the surface area

below: visualisation of the underground area